

APPLICATIONS

Cascade offers a number of fork mounted buckets that quickly convert a lift truck into a mobile scoop with dual cylinder hydraulic operation which allows for full backwards tilt making the bucket suitable for liquid products. This bucket has been manufactured inline with Australian Standards and is secured to the forklift by safety retaining chain. Unit complete with a zinc plated galvanise finish. Inside bucket width 1120mm with a Volume 0.5m³

SPECIFICATIONS

SWL	1000kg
Volume	0.5m ³
Tilt Angel	45°
H C of G	975mm
V C of G	221mm
Weight	352kg
Fork Pockets	165x65mm
Pocket Centres	750mm
Max Pressure	160Bar
Width	1200mm
Length Extended	2130mm
Length closed	1970mm
Drawing Ref	SK-27860

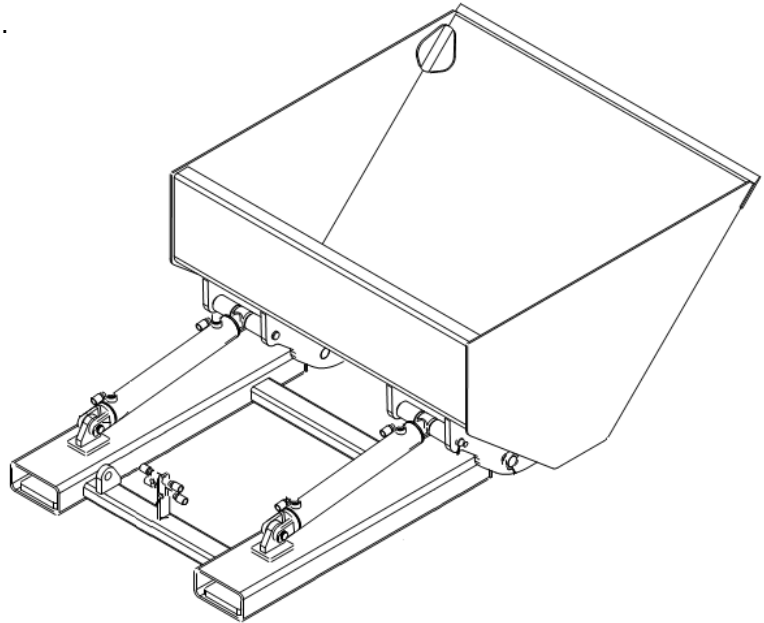

Note: All lift truck attachments affect the safe working load of a lift truck. End users should consult their lift truck supplier to ensure the lift truck is rated for use with these attachments. In the case of a slung load when lifting a jib attachment, the net lifting capacity should be 0.8 times the rating of the lift truck to allow for the swinging load. Please consult your local lift truck

