

**HANDLING
SYSTEMS
AUSTRALIA**

STRONG, DEPENDABLE ATTACHMENTS AND ACCESSORIES

2/3 Atlas Court
Welshpool WA 6106
Phone: 08 9458 7933
Web: www.hssales.net

MULTIPLE PALLET HANDLERS



Single-Double



Single-Double-Triple



Single-Double Long Forks

For more information on our product and services go to www.hssales.net

Tel: 08 9458 7933 Email: sales@hssales.net

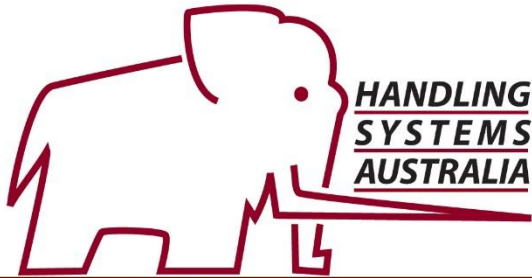

MULTIPLE PALLET HANDLERS

STRONG, DEPENDABLE ATTACHMENTS AND ACCESSORIES

Move one to four pallets with one versatile solution.

Visibly Superior

Clearer line of sight

- Large visibility window without hosing or valves gives drivers the clear sight lines they need to approach loads quickly and avoid damage
- Arm bars positioned for better functional and perceived line of sight
- Compact height improves "over the top" visibility for ground pick-up

The Clear Choice

Faster service

- Easy-to-service hydraulic cylinders enable quick servicing
- Interchangeable forks can be rotated for increased life

Longer service life

- In tests, our product lasted 2.5x longer than the previous industry standard – over time, that level of durability translates into a great value
- Full-length, fully enclosed UHMW bearings provide maximum support, reducing wear on bearing surface
- Pin mounted inner forks for optimal strength and better fork movement
- Low cost service components

More flexibility

- Load backrest can be ordered in different configurations for handling different kinds of loads
- Full line of Multiple Load Handlers can handle from one to six loads
- Additional options include various fork lengths, load stabilizers and extender models

APPLICATIONS

The Single-Double-Four Pallet Handler equipped with long forks allows you to move up to two pallets wide and two deep for a total of up to four pallets in one load. Move loads faster, minimize damage and stay competitive while helping your organization stay green by the realized energy savings. Designed for any application using pallets or containers to load trucks. Spreading the forks hydraulically allows handling of up to four pallets. Sideshifting provides added flexibility for aligning forks or pallets in tight areas.

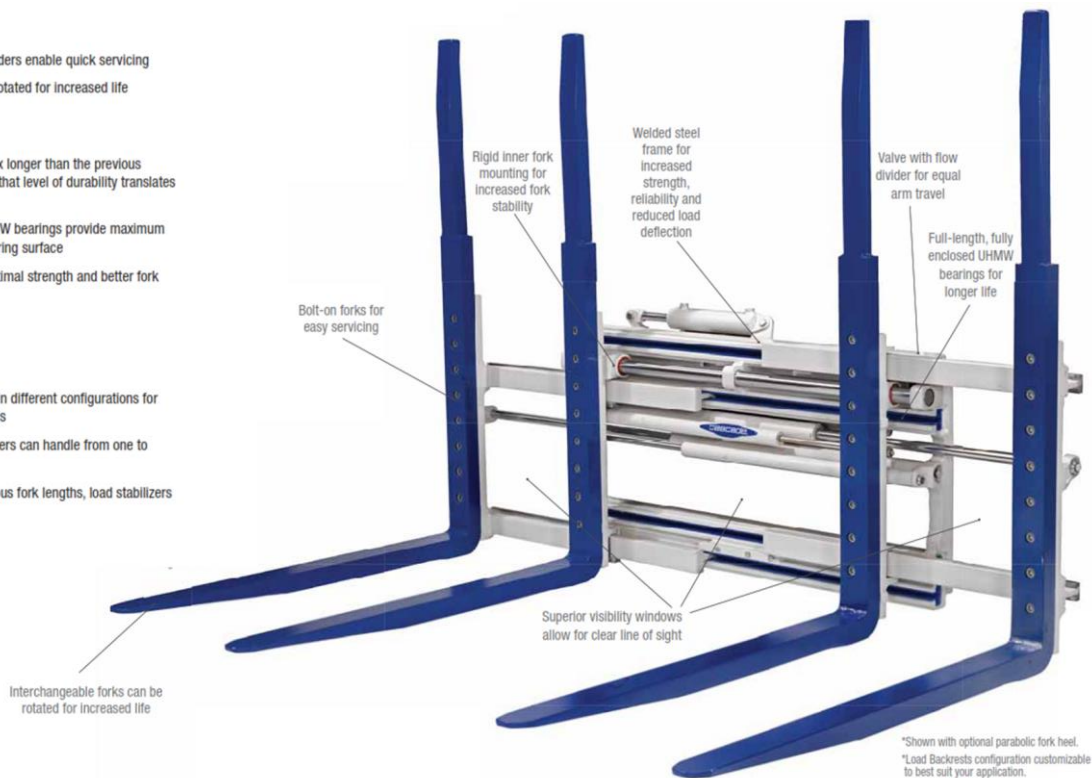

Inner fork spring mechanism to provide smooth inner fork sequencing



Optional parabolic fork heel for increased fork life



Adjustable fork stop blocks to fit different pallet sizes



OPTIONS

- Various load backrest configuration heights, fork lengths and sections
- Various fork set spreads and opening ranges
- Quick-disconnect lower hooks
- Drop shank forks—forks are lowered relative to the attachment frame
- Independent fork set control—allows moving left or right fork set independent of the opposite fork set
- Non-Sideshifting models available

For more information on our product and services go to www.hssales.net

Tel: 08 9458 7933 Email: sales@hssales.net



MULTIPLE PALLET HANDLERS

STRONG, DEPENDABLE ATTACHMENTS AND ACCESSORIES

load distribution

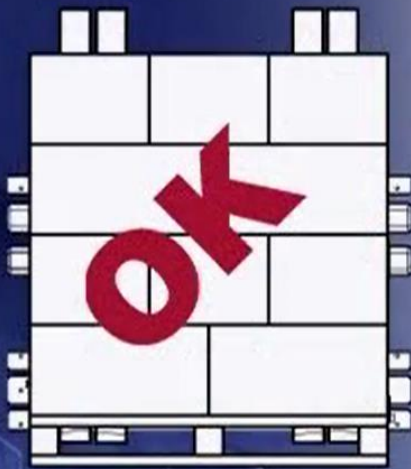

load distribution

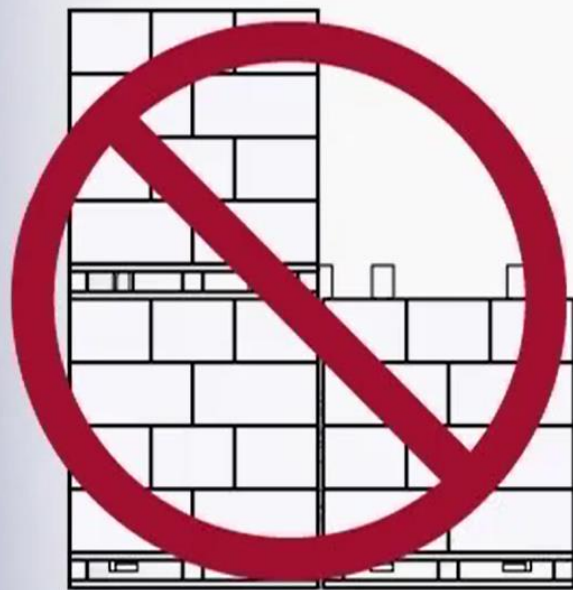

For more information on our product and services go to www.hssales.net

Tel: 08 9458 7933 Email: sales@hssales.net

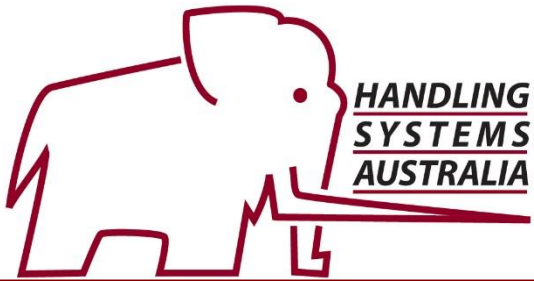

MULTIPLE PALLET HANDLERS

STRONG, DEPENDABLE ATTACHMENTS AND ACCESSORIES

load distribution

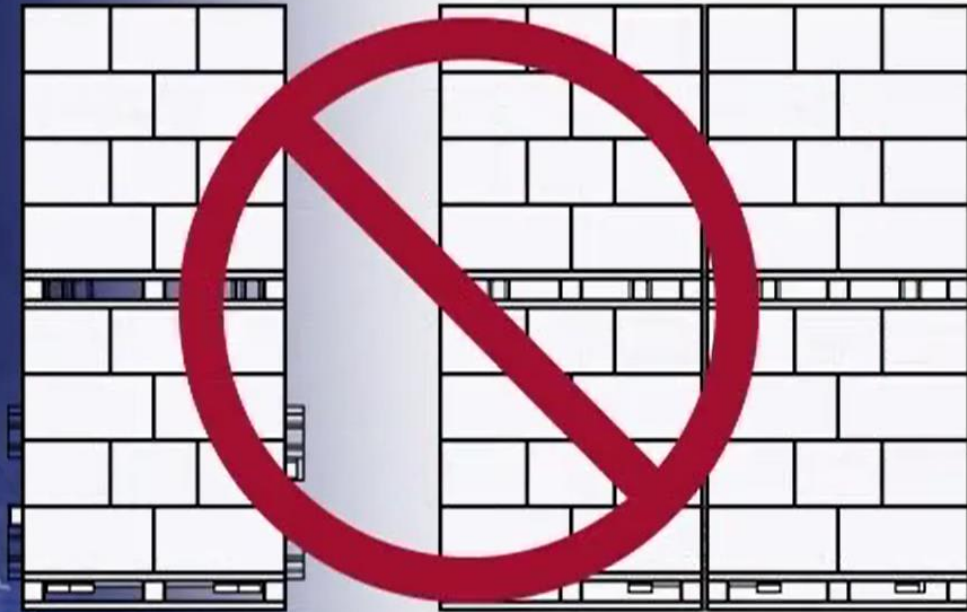

load distribution

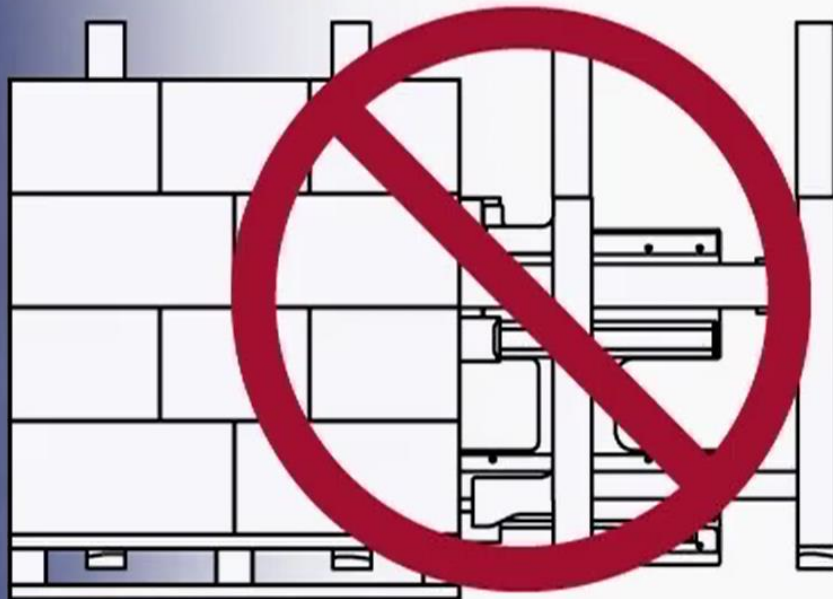

For more information on our product and services go to www.hssales.net

Tel: 08 9458 7933 Email: sales@hssales.net



**HANDLING
SYSTEMS
AUSTRALIA**

MULTIPLE PALLET HANDLERS

STRONG, DEPENDABLE ATTACHMENTS AND ACCESSORIES

Specifications

Catalogue Order No	Capacity Kg @ 600 mm Load Centre	Inner Fork Range	Outer Fork Range	Mounting Class	Fork Spread	Fork Thickness
		To	To			

Standard Twin Pallet Configuration Consists Of : A set of movable outer and manually adjusted inner forks as listed in specification sheets- Rear mounted valve - Integral sideshift - Tube type load backrest - Painted Cascade Grey.

Product Variance Request

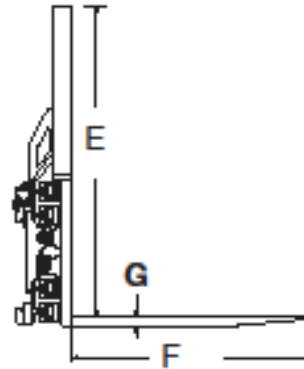
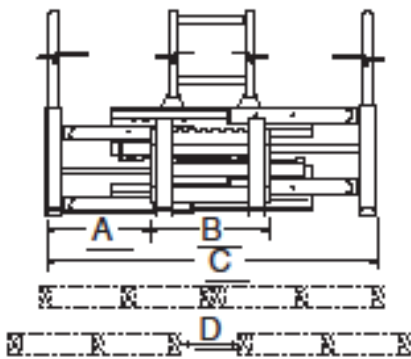

Mounting Class

- Class II
- Class III
- Quick Disconnect

Fork Set Spread	Inner Fork Range	Outer Fork Range	Pallet Spread	Overall Height	Fork Length	Fork Depth
A:	B:	C:	D:	E:	F:	G:

Pallet Information

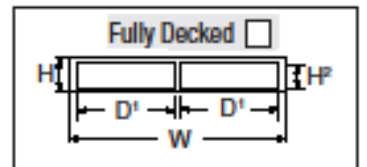
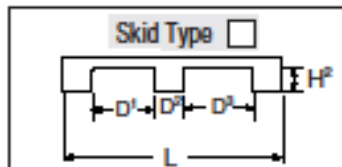
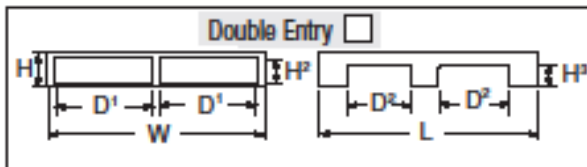

L:	W:	H:	D1:	D2:	D3:	H1:	H2:	H
----	----	----	-----	-----	-----	-----	-----	---

Other Requirements:

SEL- Specifications

Dealer Net Price: \$

Delivery Date:

SEL Catalogue Model No	Capacity Kg @ 600 mm Load Centre	Outer Fork Range-mm	Inner Fork Range-mm	Mounting Class	Effective Thickness mm	Centre of Gravity (H) mm	Centre of Gravity (V) mm	Fork Spread mm	Fork Thickness mm
		To	To						

For more information on our product and services go to www.hssales.net

Tel: 08 9458 7933 Email: sales@hssales.net