

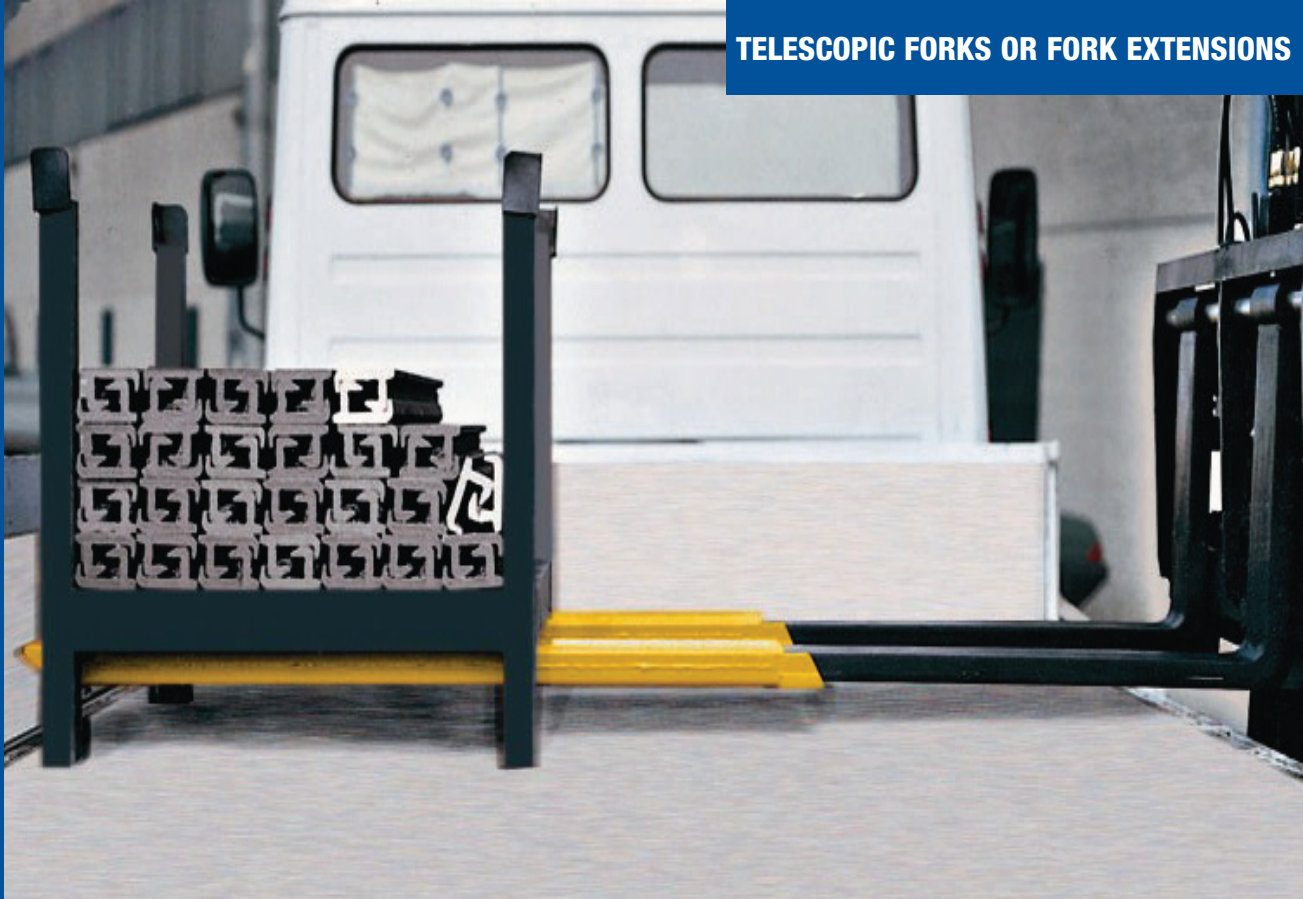

*Load and unload
trucks and
trains from one
side.*



Extend the Reach of your Lift Truck with Telescopic Forks or Fork Extensions.

APPLICATION

Increase the efficiency of your forklift truck by using Cascade Telescopic Forks or Fork Extensions.

TELESCOPIC FORKS

Trucks and trains can be loaded and unloaded from one side - no need to move back and forth to either side of the vehicle.

FORK EXTENSIONS

Fork Extensions are designed to handle different pallet sizes. Drive safely with stable, fully supported pallets. With hydraulic fork extensions, simply adjust the fork length to the pallet depth.

FEATURES

- A flow divider, supplied with each set of Telescopic Forks and Fork Extensions, assures equal fork movement.
- High grade steel and a solid cast nose improves wear ability.
- A reinforced heel design improves deflection.
- Hydraulic connections are protected behind a guard.
- ISO mounting as standard.

OPTIONS

- Special mountings available.
- Pallet Stops to prevent fork from protruding too far outside pallet.
- Can be integrated onto a Fork Positioner.
- Load Backrest to support load when moving forward.
- Wearstrips under forks to improve fork life.
- Available in a variety of fork lengths and strokes.



Proudly Distributed by:



HS Sales Pty Ltd
Unit 2 / 3 Atlas Court
Welshpool WA
(08) 9458 7933
www.hssales.net
sales@hssales.net

cascade
EUROPE

TELESCOPIC FORKS OR FORK EXTENSIONS

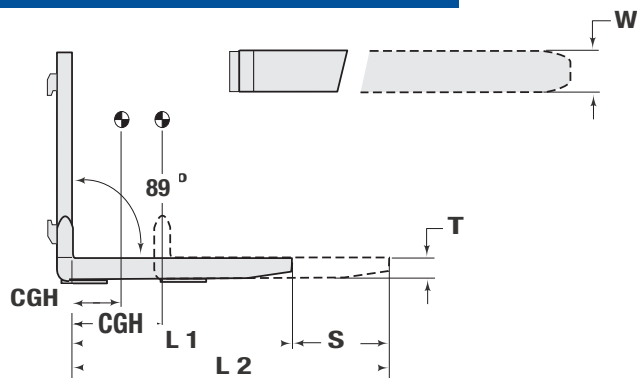

Pallet stop

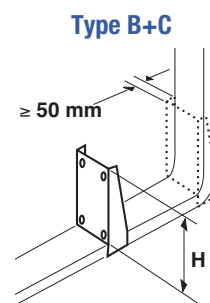
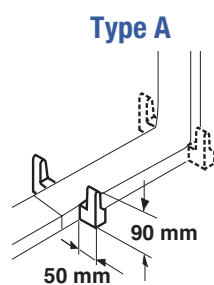

H dimension:
Type B = 400 mm high
Type C = 850 mm high

| Model | Capacity @ 600 mm Load Center | Capacity @ 1750 mm Load Center | Fork Length L1 / L2 (mm) | Fork dimension W x T (mm) | Stroke S=L2-L1 | Center of Gravity | Center of Gravity | Mass kg | Mounting Class |
|---|-------------------------------|--------------------------------|-----------------------------|------------------------------|-------------------|-------------------|-------------------|------------|----------------|
| | kg | kg | | | | CGH 1 | CGH 2 | | |
| Standard model TFQ, telescopic with load | | | | | | | | | |
| 55B-TFQ-A041 | 2500 | 850 | 1100 / 1850 | 170 x 56 | 750 | 390 | 500 | 205 | 2A |
| 55B-TFQ-A042 | 2500 | 850 | 1200 / 2050 | 170 x 56 | 850 | 440 | 560 | 220 | 2A |
| 55B-TFQ-A043 | 2500 | 850 | 1350 / 2350 | 170 x 56 | 1000 | 500 | 650 | 240 | 2A |
| 77B-TFQ-B041 | 3500 | 1200 | 1100 / 1850 | 170 x 56 | 750 | 400 | 490 | 240 | 3A |
| 77B-TFQ-B042 | 3500 | 1200 | 1200 / 2050 | 170 x 56 | 850 | 440 | 550 | 255 | 3A |
| 77B-TFQ-B043 | 3500 | 1200 | 1350 / 2350 | 170 x 56 | 1000 | 500 | 640 | 275 | 3A |
| 100B-TFQ-B041 | 4500 | 1540 | 1100 / 1850 | 170 x 56 | 750 | 380 | 480 | 210 | 3A |
| 100B-TFQ-B042 | 4500 | 1540 | 1200 / 2050 | 170 x 56 | 850 | 430 | 550 | 225 | 3A |
| 100B-TFQ-B043 | 4500 | 1540 | 1350 / 2350 | 170 x 56 | 1000 | 500 | 640 | 245 | 3A |
| 130B-TFQ-C041 | 5800 | 1985 | 1100 / 1850 | 170 x 65 | 750 | 400 | 500 | 250 | 4A |
| 130B-TFQ-C042 | 5800 | 1985 | 1200 / 2050 | 170 x 65 | 850 | 440 | 570 | 270 | 4A |
| 130B-TFQ-C043 | 5800 | 1985 | 1350 / 2350 | 170 x 65 | 1000 | 500 | 660 | 295 | 4A |
| 175B-TFQ-C041 | 7700 | 2640 | 1100 / 1850 | 225 x 65 | 750 | 360 | 470 | 370 | 4A |
| 175B-TFQ-C042 | 7700 | 2640 | 1200 / 2050 | 225 x 65 | 850 | 400 | 530 | 395 | 4A |
| 175B-TFQ-C043 | 7700 | 2640 | 1350 / 2350 | 225 x 65 | 1000 | 460 | 620 | 425 | 4A |
| 230B-TFQ-C041 | 10500 | 3600 | 1100 / 1850 | 225 x 75 | 750 | 360 | 460 | 435 | 4A |
| 230B-TFQ-C042 | 10500 | 3600 | 1200 / 2050 | 225 x 75 | 850 | 400 | 520 | 460 | 4A |
| 230B-TFQ-C043 | 10500 | 3600 | 1350 / 2350 | 225 x 75 | 1000 | 470 | 600 | 500 | 4A |

Slim line model TFF, telescopic with load

| | | | | | | | | | |
|--------------|------|------|-------------|----------|------|-----|-----|-----|----|
| 70B-TFF-B041 | 3200 | 1095 | 1100 / 1850 | 170 x 47 | 750 | 370 | 480 | 190 | 3A |
| 70B-TFF-B042 | 3200 | 1095 | 1200 / 2050 | 170 x 47 | 850 | 410 | 540 | 200 | 3A |
| 70B-TFF-B043 | 3200 | 1095 | 1350 / 2350 | 170 x 47 | 1000 | 470 | 630 | 215 | 3A |

Fork extensions model TFE, for europallets and international pallets

| | | | | | | | | | |
|---------------|------|--|-------------|----------|-----|-----|-----|-----|----|
| 55B-TFE-A051 | 2500 | | 800 / 1200 | 170 x 55 | 400 | 260 | 310 | 170 | 2A |
| 55B-TFE-A052 | 2500 | | 1000 / 1200 | 170 x 55 | 200 | 350 | 380 | 195 | 2A |
| 70B-TFE-B051 | 3200 | | 800 / 1200 | 170 x 47 | 400 | 245 | 305 | 155 | 3A |
| 70B-TFE-B052 | 3200 | | 1000 / 1200 | 170 x 47 | 200 | 330 | 375 | 175 | 3A |
| 77B-TFE-B051 | 3500 | | 800 / 1200 | 170 x 56 | 400 | 260 | 310 | 195 | 3A |
| 77B-TFE-B052 | 3500 | | 1000 / 1200 | 170 x 56 | 200 | 350 | 380 | 225 | 3A |
| 100B-TFE-B051 | 4500 | | 800 / 1200 | 170 x 55 | 400 | 255 | 300 | 175 | 3A |
| 100B-TFE-B052 | 4500 | | 1000 / 1200 | 170 x 55 | 200 | 340 | 370 | 200 | 3A |

Telescopic forks model TFT, for reachtrucks

| | | | | | | | | | |
|--------------|------|-----|-------------|----------|------|-----|-----|-----|----|
| 40B-TFT-A061 | 1800 | 615 | 1100 / 1850 | 140 x 55 | 750 | 390 | 500 | 170 | 2A |
| 40B-TFT-A062 | 1800 | 615 | 1200 / 2050 | 140 x 55 | 850 | 440 | 560 | 185 | 2A |
| 40B-TFT-A063 | 1800 | 615 | 1350 / 2350 | 140 x 55 | 1000 | 500 | 550 | 200 | 2A |
| 55B-TFT-A061 | 2500 | 850 | 1100 / 1850 | 140 x 47 | 750 | 370 | 480 | 160 | 2A |
| 55B-TFT-A062 | 2500 | 850 | 1200 / 2050 | 140 x 47 | 850 | 410 | 540 | 165 | 2A |
| 55B-TFT-A063 | 2500 | 850 | 1350 / 2350 | 140 x 47 | 1000 | 470 | 630 | 180 | 2A |

HYDRAULIC FUNCTIONS

| Model | Hydraulic Functions | Truck Aux. Valves Required |
|-----------------|---------------------|----------------------------|
| TFQ,TFF,TFE,TFT | 1 | 1 |

HYDRAULIC FLOW & PRESSURE

| Min. Flow | Recommended Flow | Max. Flow | Max. Pressure |
|-----------|------------------|-----------|---------------|
| 10 LPM | 12 LPM | 15 LPM | 220 BAR |

Cascade Europe • Damsluisweg 56 • PO Box 3009 • 1300 EL, Almere, Netherlands • Tel +31 (0)36 54 92 950 • Fax +31 (0)36 54 92 974
 Cascade (UK) Ltd. • 3 Kellbrook Road • Parkhouse Industrial Estate • Openshaw, Manchester M11 2DD, England • Tel 0044 (0) 800 243015 • Fax +0044 (0) 161 438 4055

cascade
EUROPE

Cascade and Worldfork are registered trademarks of Cascade Corporation.
 © Cascade Corporation 2009. All rights reserved.

www.cascorp.com

Form xxxxxxGB 03/09