

1 2 3 4 5 6 7 8 9 10

A

B

C

D

E

F

G

H

I

A

B

C

D

E

F

G

H

I

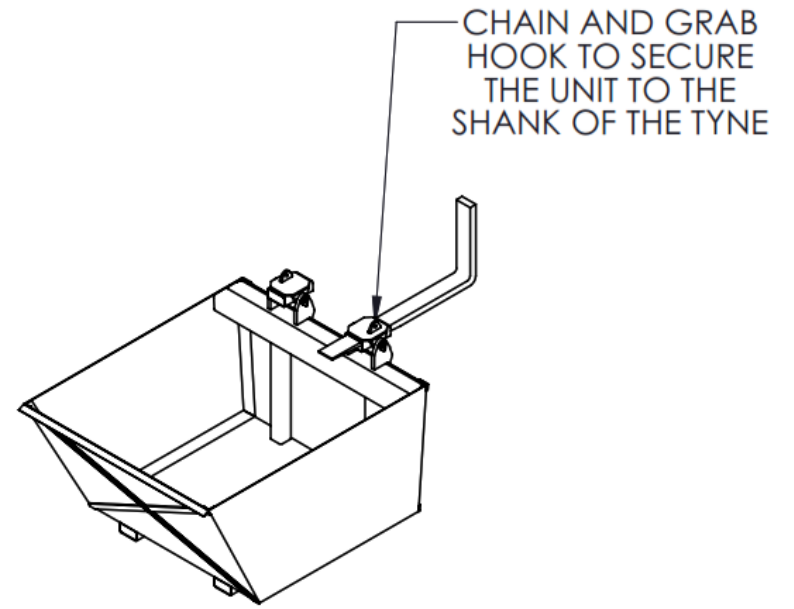
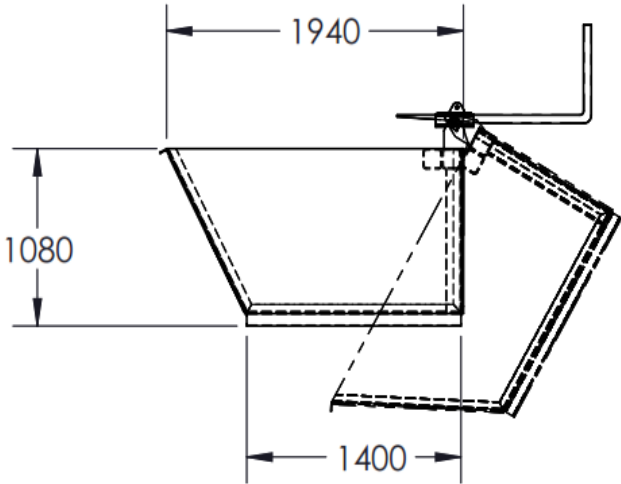

ESTIMATED SPECIFICATIONS

1. SWL: 2500KGS
2. MASS: 600KGS
3. OVERALL DIMENSIONS
4. 1940x1080x1640mm (LxHxW)
5. AS PER AS2359.1
6. PAINTED BLACK FINISH

REV	DATE	DESCRIPTION

DRN: HSRD	H.S. Research & Development	HSRD 1620
SCALE: DNS	Unit 2/ 3 Atlas Court, Welshpool, WA 6106 Ph: (08) 9458 7933 Fax: (08) 9458 1351	
CKD:	MATERIAL:	DWG NO:
SCALE:		DIMENSIONS IN MILLIMETERS

A4

1 2 3 4 5 6 7 8 9 10