

HSTS Tarp Spreader

SPECIFICATIONS

SWL:	200kg
Load Centre:	600mm
Weight:	160kg
H C of G:	500mm
V C of G:	400mm
Design:	HSRD-167

FEATURES

- ■ Safety retaining chain
- ■ 150x50 Fork Access
- ■ Supplied with rating plate as per AS23591
- ■ Finished in safety yellow paint.
- ■ Australian Made

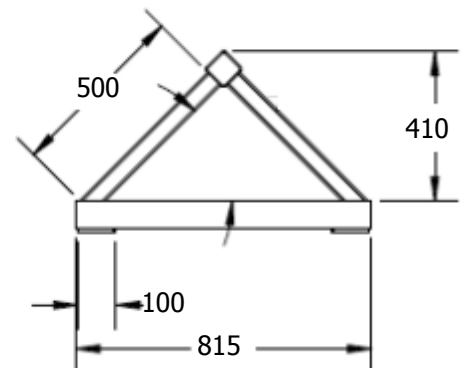
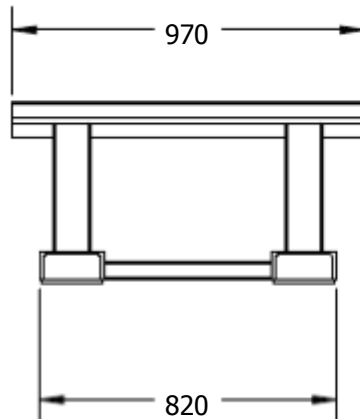
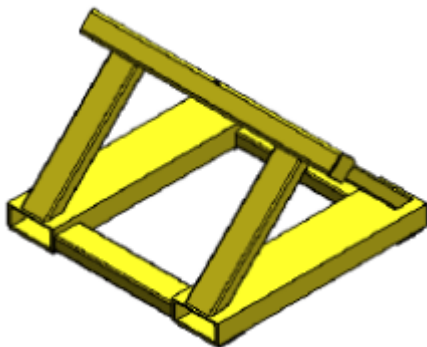
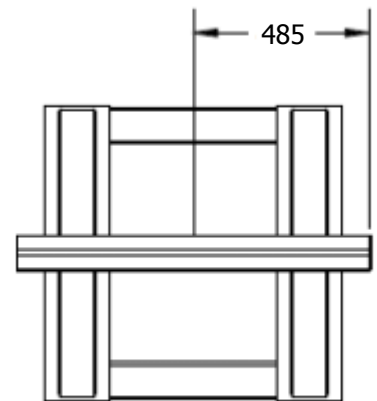
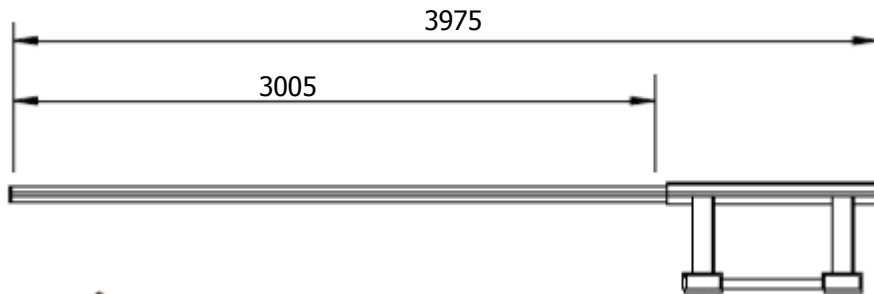
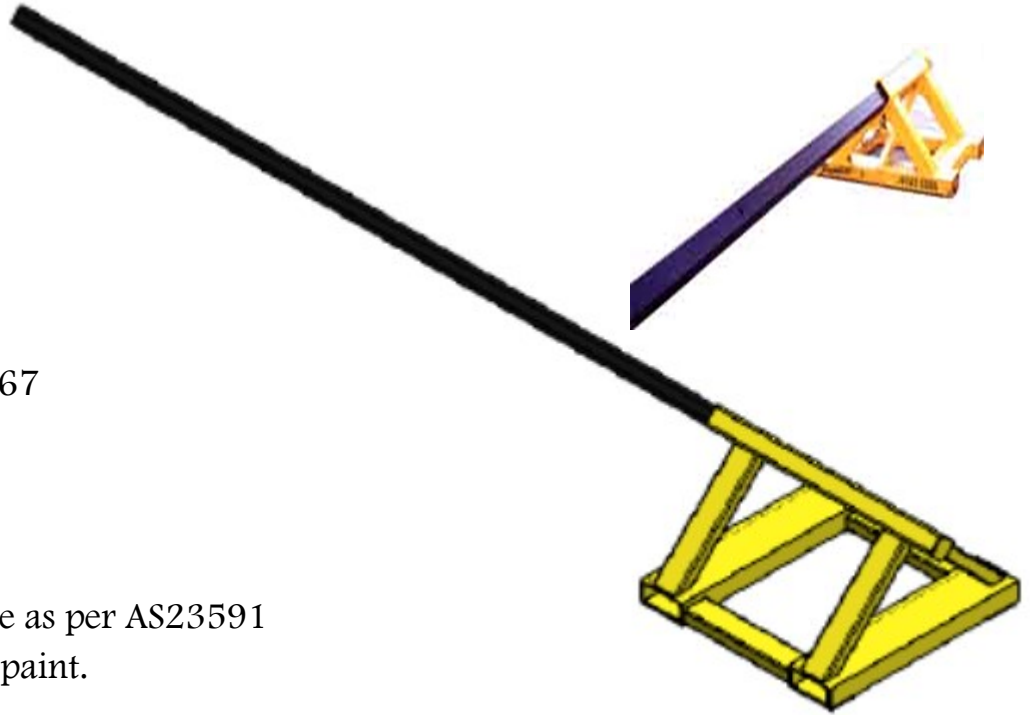

For more information on our products and services go to www.hssales.net

Tel 08 9458 7933 2/3 Atlas Court Welshpool WA Fax 08 9458 1351 Email sales@hssales.net