

## APPLICATIONS

This Hydraulic Drum Tipper is designed to tip 205 litre Drums. With 1 tonne lift capacity, this attachment is ideal for the recycling industry and for mining applications. This lifter is able to pick a single drum from a pallet of 4 without disturbing the other 3 drums and decant the contents from the operator's seat. This unit is fitted with quick connect couplings for connection to the 3rd and 4th Forklift hydraulic valves.

The standard finish on this attachment is galvanized.

## SPECIFICATIONS

Max Fork Section	185 x 65mm
SWL	1000kgs
Load Centre	600mm
H C of G	700mm
V C of G	194mm
Weight	175kg
Pocket Centres	874mm

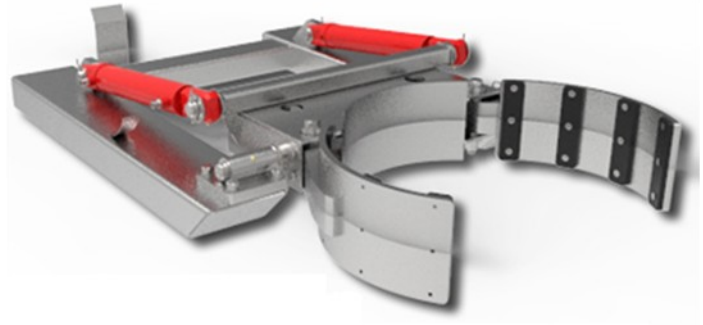

*Note: All lift truck attachments affect the safe working load of a lift truck.. Users should consult with their lift truck supplier to ensure the lift truck is rated for use with these attachments.*

