

APPLICATIONS

Cascade offers a number of fork mounted jib cranes that quickly convert a lift truck into a mobile crane to easily move non-palletised product. A variety of Jib Crane models for practically any application to increase lift truck versatility. Models include Multi-Angled, Flat, Slip-On, or Carriage- Mounted, allowing for effective slinging of loads beneath a hook.

The standard finish on this attachment is zinc.

SPECIFICATIONS

SWL	9500kg
H C of G	829mm
V C of G	193mm
Weight	592kg
Fork Pockets	200x90mm
Pocket Centres	790mm
Drawing Ref	SK-56118

DIMENSIONS

Length—Closed	2190mm
Length— Extended	3710mm
Height	670mm
Width	1080mm

FEATURES AND BENEFITS

- Safety Swivel Hook supplied standard
- Fork Arm Retaining Toggles or retaining chain
- Zinc plated finish
- Designed in accordance with AS2359
- Multiple load positions

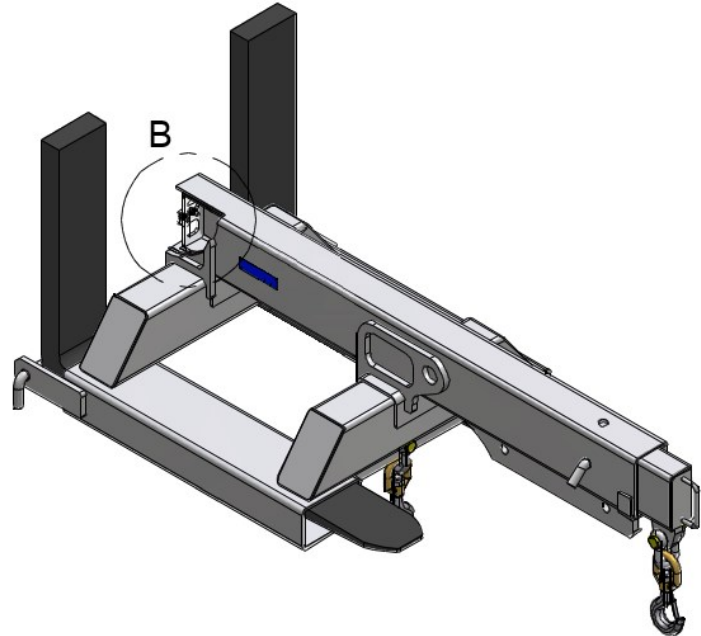

NOTE: All lift truck attachments affect the safe working load of a lift truck. Users should consult their lift truck supplier to ensure the lift truck is rated for use with these attachments. In the case of a slung load when lifting a jib attachment, the net lifting capacity should be 0.8 times the rating of the lift truck to allow for the swinging load. Please consult your local lift truck supplier.

SAFE WORKING LOAD (SWL) PER POSITION								
POSITION	1	2	3	4	5	6	7	8
SWL (kg)	9500	8550	7600	6600	5000	2600	1520	960
EXTENSION (mm)	920	1380	1805	2045	2425	2805	3185	3565

