



A tipping clamp designed for magnum and T loaded appliances in trailers.

APPLICATIONS

Designed for magnum and T loaded appliances in trailers. Articulating pads securely hold the load without damage. The sideshifting feature allows the operator to easily maneuver in and out of the product being handled.

FEATURES

- Carton Guard articulating pads for improved clamp force distribution
- Sideshifting with cross over relief for efficient product handling
- Cushion stop tipping cylinders for smooth operation
- Increased opening range for optimum loading and unloading capability

A forward tipping, articulating clamp for handling appliances.

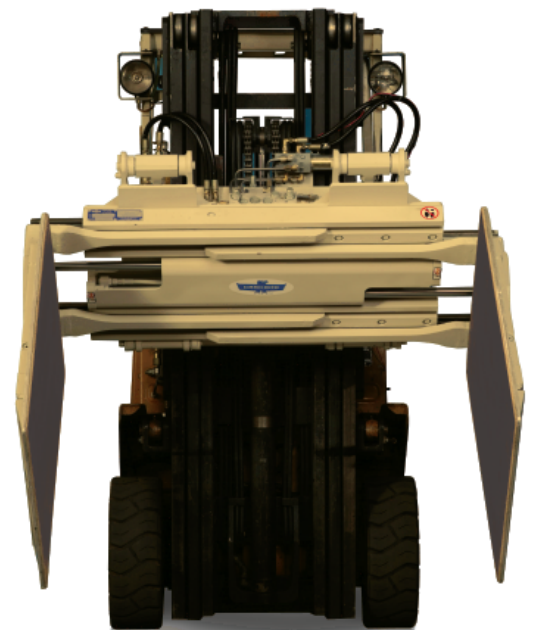

Proudly Distributed by:



HS Sales Pty Ltd
Unit 2 / 3 Atlas Court
Welshpool WA
(08) 9458 7933
www.hssales.net
sales@hssales.net

TIPPING CLAMP

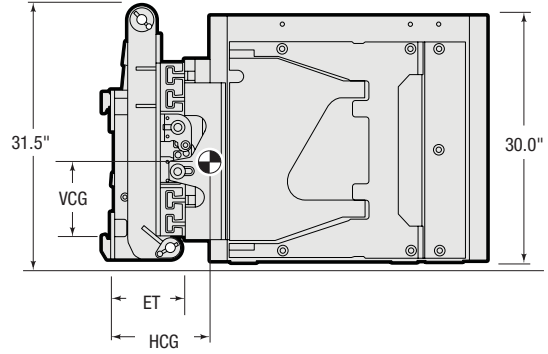
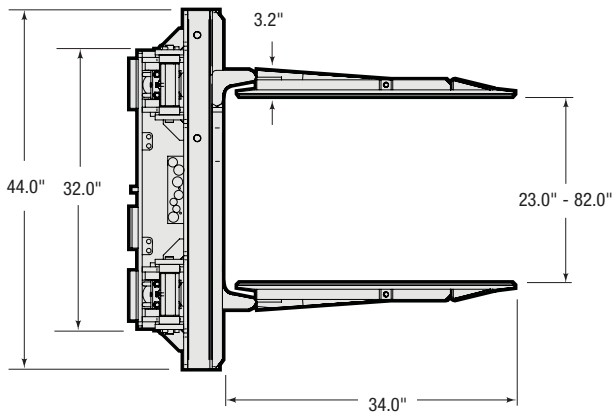

Capacity @ 17" (432 mm) Load Center		Opening Range	Catalog Order No.	Mtg. Class	Min. Truck Carriage Width	Weight		Effective Thickness	Horizontal Ctr. of Gravity	Vertical Ctr. of Gravity	Arm Height	Arm Length	
lbs	kg					lbs	kg					ET	HCG
1500	680	23"-82"	15D-CCU	II	32.5"	1,725	782	10.6"	15.2"	13.6"	30"	34"	

HYDRAULIC FLOW AND PRESSURE

Minimum	Recommended	Maximum	Max. Pressure
5 GPM	5.5 GPM	8 GPM	2,300 PSI/159 bar

HYDRAULIC FUNCTIONS

Hydraulic Functions	Truck Auxiliary Valves Required
3	2

MOUNTING CLASS INFORMATION

Mounting Class	Truck Capacity
II	2,000-5,500 lbs.

This unit is solenoid equipped for the tipping function. A two function hydraulic supply is required. The sideshift and clamp functions are actuated directly with the auxiliary valves. The tipping function is actuated by depressing the solenoid button and then actuating the sideshift valve. The control knob kit with a push button or the Low Profile Switch kit is included with the attachment. Please specify at time of order entry. Requires a four-way auxiliary valve on the truck, electrical cable, and four hose installation kit.

IMPORTANT: Solenoid voltage must match truck voltage. This unit is equipped with a 12 volt solenoid. If you require a different voltage, please specify at time of order entry.

Proudly Distributed by:



HS Sales Pty Ltd
 Unit 2 / 3 Atlas Court
 Welshpool WA
 (08) 9458 7933
www.hssales.net
sales@hssales.net