

APPLICATIONS

Cascade offers a number of fork mounted jib cranes that quickly convert a lift truck into a mobile crane to easily move non-palletised product. A variety of Jib Crane models for practically any application to increase lift truck versatility. Models include Multi-Angled, Flat, Slip-On, or Carriage- Mounted, allowing for effective slinging of loads beneath a hook.

The standard finish on this attachment is zinc.

SPECIFICATIONS

SWL	4500kg Max
H C of G	513mm
V C of G	10mm
Weight	106kg
Fork Pockets	185x65mm
Pocket Centres	290mm
Drawing Ref	SK-27884

Note: All lift truck attachments affect the safe working load of a lift truck. End users should consult their lift truck supplier to ensure the lift truck is rated for use with these attachments. In the case of a slung load when lifting a jib attachment, the net lifting capacity should be 0.8 times the rating of the lift truck to allow for the swinging load. Please consult your local lift truck

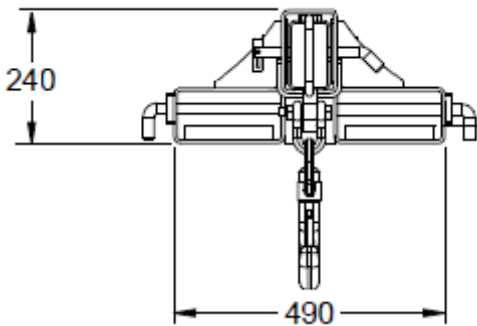

Position	SWL	Load Cente
1	4500kg	670mm
2	2900kg	1165mm
3	1300kg	1545mm
4	750kg	1925mm

