

1 2 3 4 5 6 7 8 9 10

A

B

C

D

E

F

G

H

I

A

B

C

D

E

F

G

H

I

Top section to be moveable by hydraulic cylinders

Hydraulic Jacks ; 5T Capacity

ESTIMATED SPECIFICATIONS

1. SWL: 4000KGS
2. MASS: 550KGS
3. AS PER AS3990
4. 200MM ADJUS LIFT
5. 4X CASTORS
6. SAFETY YELLOW PAINTED FINISH
7. FORK POCKETS 150X65MM

1T lifting lug for pulling the table while loaded

PU casters with 2000 Kg capacity Casters are locking type

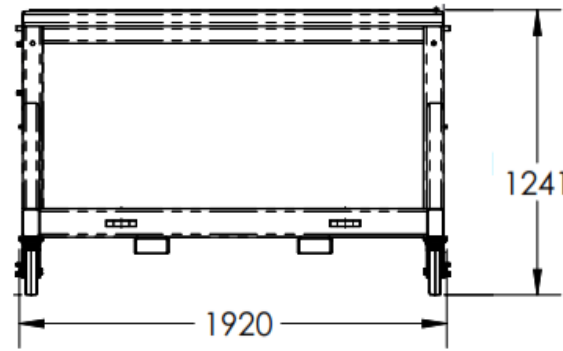
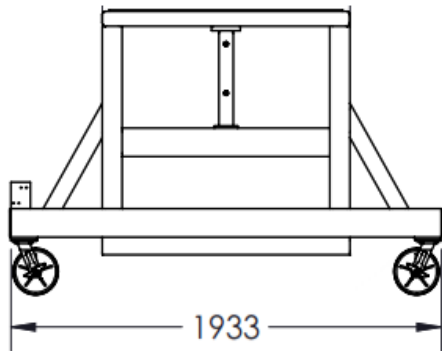
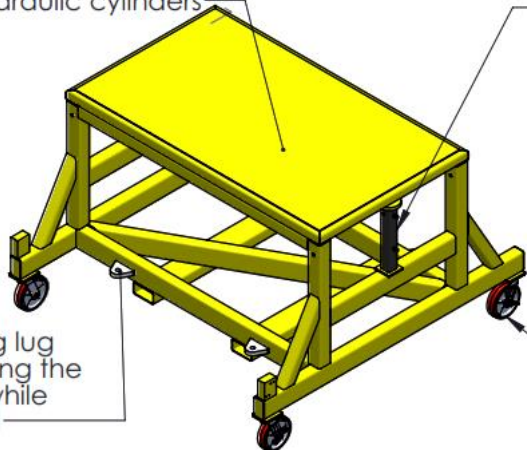

REV	DATE	DESCRIPTION

DRN: HSRD	H.S. Research & Development	HSRD 1437
SCALE: DNS	Unit 2/ 3 Atlas Court, Welshpool, WA 6106 Ph: (08) 9458 7933 Fax: (08) 9458 1351	
CKD:	MATERIAL:	DWG NO:
SCALE:		DIMENSIONS IN MILLIMETERS

A4

1 2 3 4 5 6 7 8 9 10