

HSDRM-C Manual Drum Handler - Chain Operated

Designed to safely and efficiently handle 205L drums. The 10' pull-chain loop allows the forklift operator to empty content from the safety of the drivers seat, increasing production time and employee safety.

SPECIFICATIONS

SWL:	350kgs
Weight:	70kgs
HC of G:	670mm
VC of G	250mm
Load Centre:	1030mm
Pocket Centres:	620mm
Fork Size:	150x65mm

FEATURES

- 10' pull-chain operation
- Safety Yellow enamel finish
- Supplied with rating plate
- Slip on fork mount



***NOTE:** All lift truck attachments affect the safe working load of a lift truck. Users should consult with their lift truck supplier to ensure the lift truck is rated for use with these attachments.*

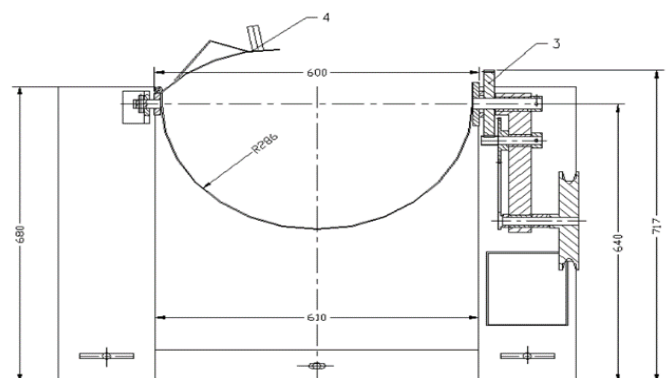
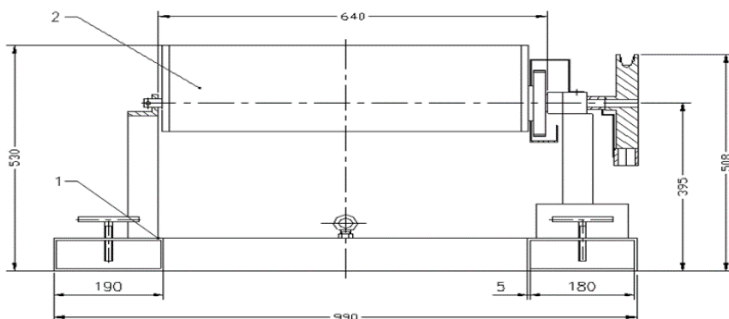

For more information on our products and services go to www.hssales.net

Tel 08 9458 7933 2/3 Atlas Court Welshpool WA Fax 08 9458 1351 Email sales@hssales.net