

SPECIFICATIONS:

MODEL NUMBER: 22A-PHC-F-0100
 CAPACITY AT LOAD CENTRE: 2200 kg X 600 MM
 EXTERNAL DIMENSIONS: 1215 X 1039 X1362 MM
 WEIGHT: 226. kg
 FORK SIZE: 100 X 50 MM
 USABLE FORK LENGTH:1050 MM
 HORZ. COG: REFER TO DRAWING
 VERT. COG: REFER TO DRAWING

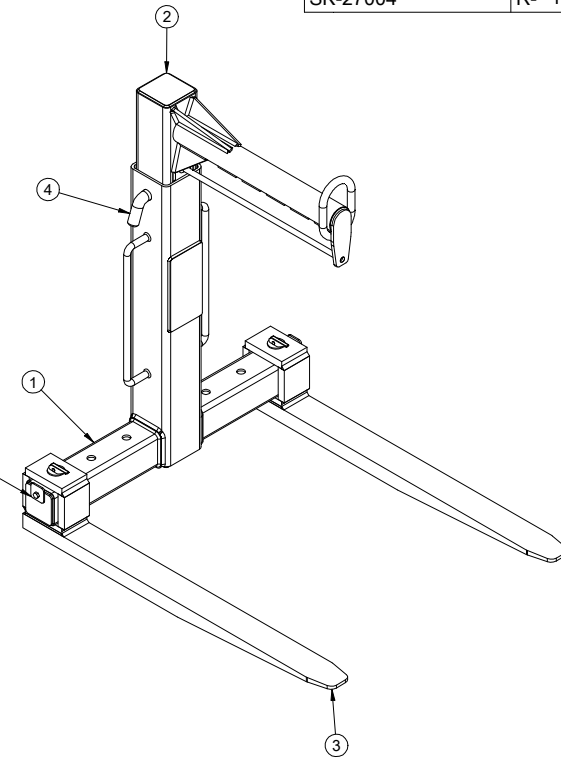

TORQUE TO 38 Nm
 PER CPS 1

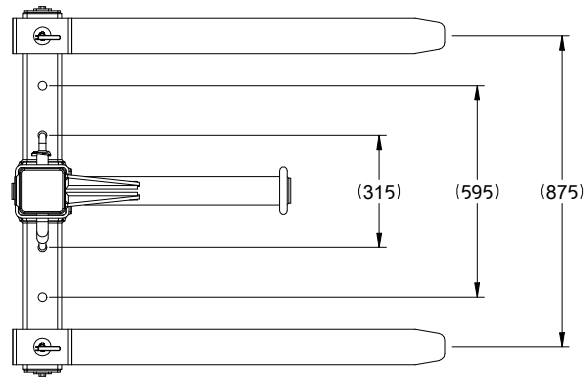
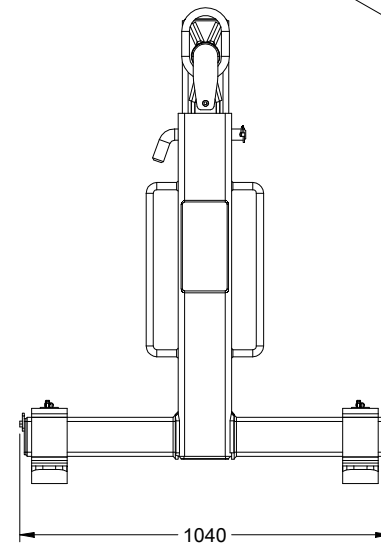
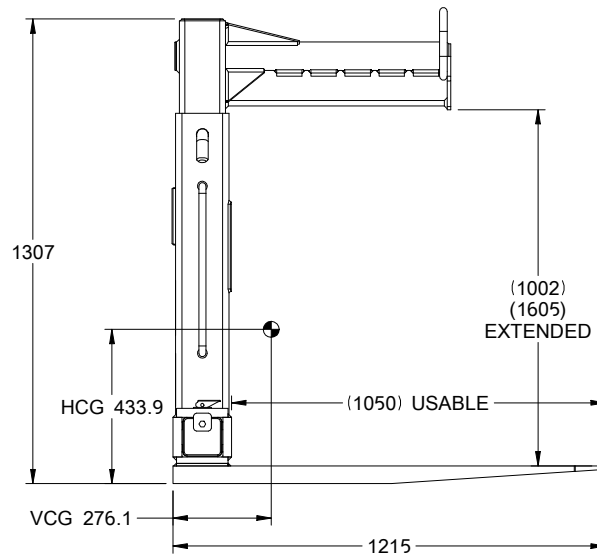
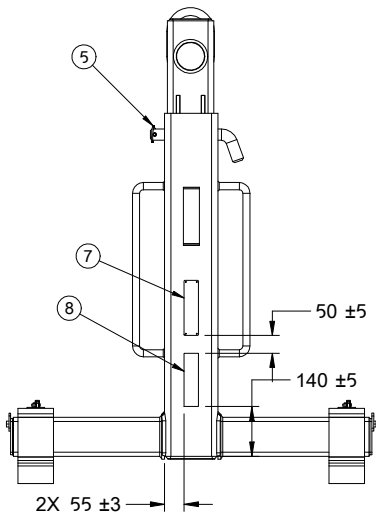

o	o-o	PN	-----
1	1	1879822	VERTICAL SUPPORT WELDMENT
2	1	1879859	ADJUSTABLE SUPPORT WELDMENT
3	2	1879823	FORK WELDMENT
4	1	1879843	ROUND
5	1	1879986	PIN
6	2	1878274	OUTER STOP ASSEMBLY
7	1	1854228	NAMEPLATE
8	1	1854268	DECAL, STATUTORY WARNING

HS Part No: 22A-PHC-A02 Adjustable Pallet Hook

A-PIC REV	LISTED	<input checked="" type="checkbox"/> DCHEW <input checked="" type="checkbox"/> BHUDSPET <input checked="" type="checkbox"/>
SEE CASCADE ENGINEERING STANDARDS FOR DRAFTING CONVENTIONS. UNLESS OTHERWISE SPECIFIED ALL DIMENSIONS ARE IN MILLIMETERS. ALL POSITION TOLERANCES APPLY AT Ⓞ. ENVELOPE REQUIREMENT, Ⓞ, APPLIES.		2021-02-04 226. kg

METRIC THIS DRAWING IS THE PROPERTY OF CASCADE AND CONTAINS CONFIDENTIAL INFORMATION. DO NOT REPRODUCE OR USE WITHOUT WRITTEN APPROVAL.	
PALLET HOOK LAYOUT	
MANUALLY ADJUSTABLE	
22A-PHC-F-0100	
1	SK-27004
R- 1	