

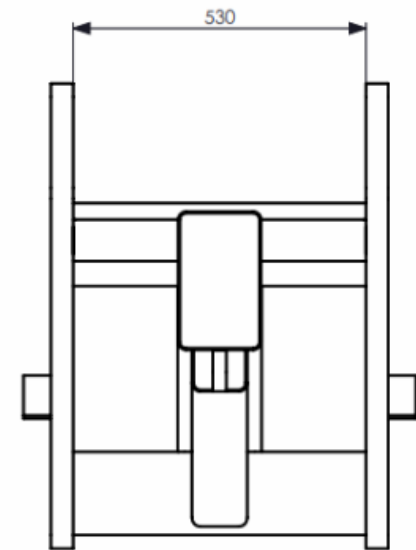

LOAD CHART (WLL) WORKING LOAD LIMIT	
POSITION 1:	4000kgs @ 600mm
POSITION 2:	2250kgs @ 1050mm
POSITION 3:	1500kgs @ 1500mm

ESTIMATED SPECIFICATIONS
 SWL: 4000kgs @ 600mm
 MASS: 255KGS
 HCG: 471MM
 VCG: -330MM
 LL: 0MM
 MACHINE: CAT 930

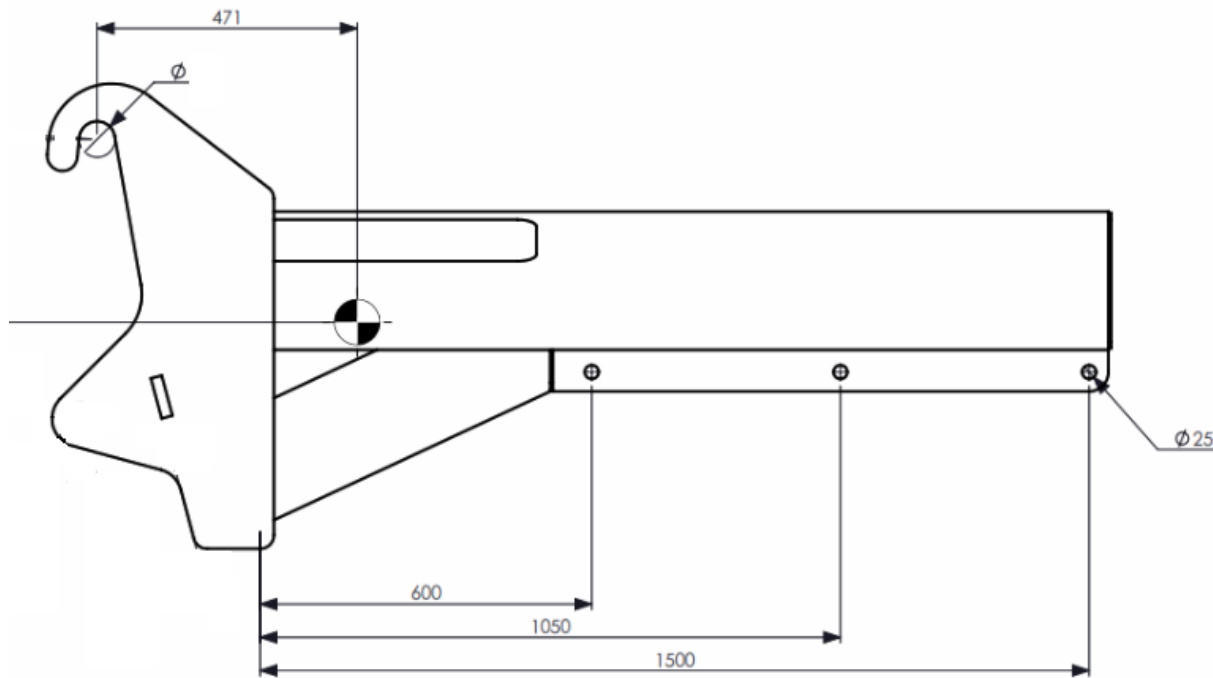

REV	DATE	DESCRIPTION

DRN: HSRD	H.S. Research & Development	HSRD 889
SCALE: DNS	Unit 2/ 3 Atlas Court, Welshpool, WA 6106 Ph: (08) 9458 7933 Fax: (08) 9458 1351	
CKD:	MATERIAL:	DWG NO:
 SCALE:		DIMENSIONS IN MILLIMETERS

A4