

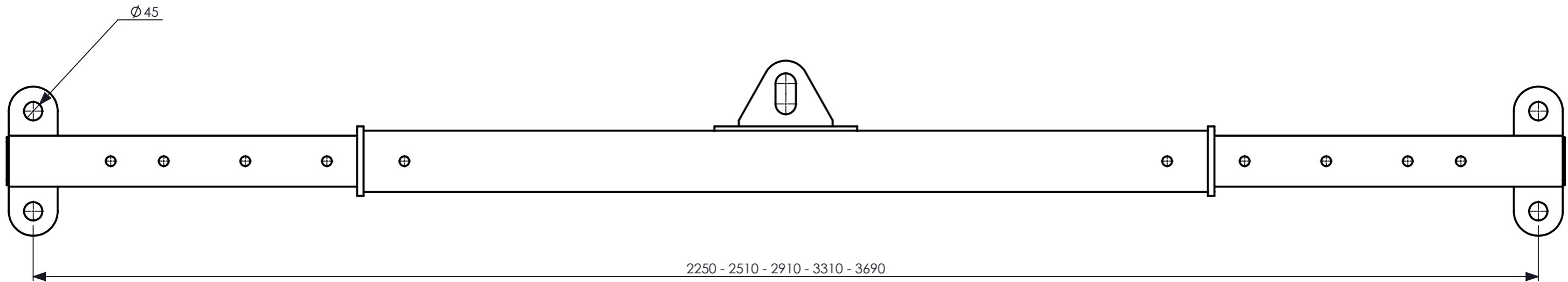

POSITION	MAX LIFTING BEAM	MAX SPREADER
2250 mm	2600 kg	12000 kg
2510 mm	2300 kg	12000 kg
2910 mm	2000 kg	12000 kg
3310 mm	1750 kg	12000 kg
3690 mm	1600 kg	12000 kg

NOTES:  
WLL 12T MAX  
DESIGN TO SUIT 14T TEREX FRANNA CRANE  
DESIGN TO AS 4991, 3990 & 4100  
ALL WELDS TO AS 1554.1 SP  
REMOVE WELD SPATTER  
GRIND SHARP EDGES  
PAINT GOLDEN YELLOW  
MARK WLL ON BEAM  
TO SUIT BARE CO B405 DRAWBAR PIN  
TARE WEIGHT 110kg



	DATE	 <b>HS RESEARCH &amp; DEVELOPMENT PTY LTD</b> 2/3 ATLAS COURT, WELSHPOOL WA 6106 Ph: +61 (08) 9458 7933 F: +61 (08) 9458 1351		
	23/10/2020			
	DRAWN	<b>12T EXTENDABLE COMBINATION SPREADER BEAM 2.2-3.6M</b>		
	CM			
CHECKED	DRAWING STATUS	<b>H.S.RD 494</b>		<b>A3</b>
	FOR CONSTRUCTION			
	SCALE: DO NOT SCALE	DIMENSIONS IN MILLIMETRES	SHEET 1 OF 2	