

LOAD CHART (WLL) WORKING LOAD LIMIT
 POSITION 1: 3000kgs @ 600mm

ESTIMATED SPECIFICATIONS
 SWL: 3000kgs @ 600mm
 MASS: 152KGS
 HCG: 241MM
 VCG: -156MM
 LL: 0MM
 MACHINE: Manitou 732

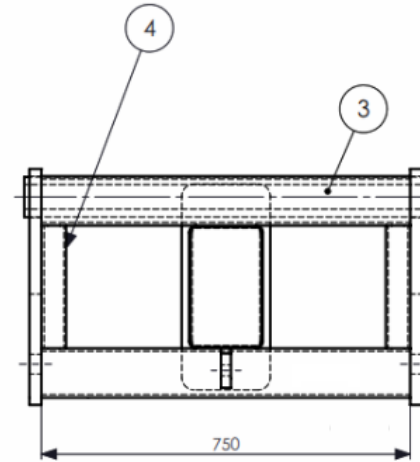
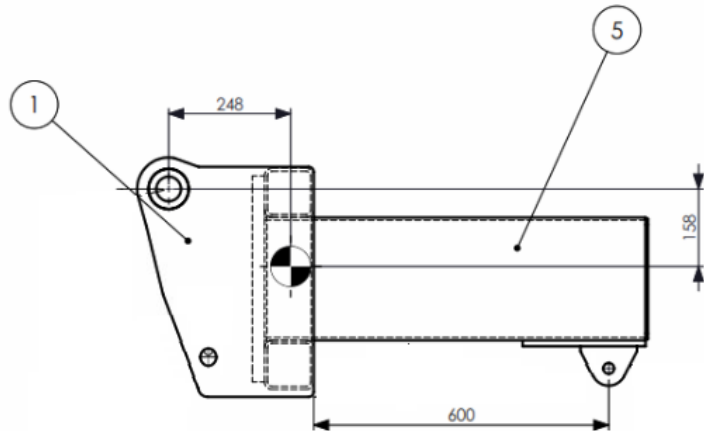
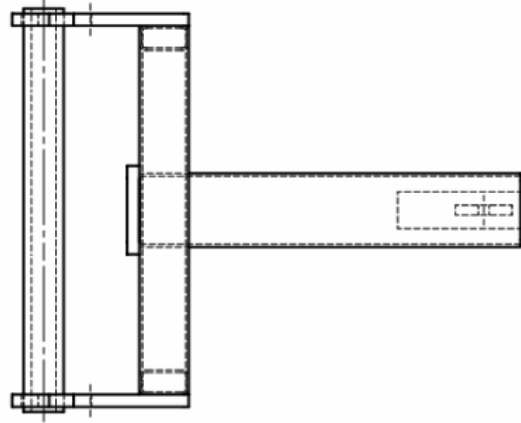

REV	DATE	DESCRIPTION

DRN: HSRD	H.S. Research & Development	HSRD 963
SCALE: DNS	Unit 2/ 3 Atlas Court, Welshpool, WA 6106 Ph: (08) 9458 7933 Fax: (08) 9458 1351	
CKD:	MATERIAL:	DWG NO:

SCALE: DIMENSIONS IN MILLIMETERS **A4**