

o	o-o	PN	----
1	1	1874663	WELDMENT, CONTAINER RAMP
2	2	1862514	0.5 TON SAFETY CHAIN ASSY
3	1	1854228	NAMEPLATE
4	1	1854268	DECAL, STATUTORY WARNING

DATA PLATE	
MODEL NUMBER	65A-MRC-F-0125
SAFE WORK LOAD	6500 kg
WEIGHT	262 kg (B)
LENGTH	1550 mm
WIDTH	2000 mm
POCKET SIZE	160 X 60 mm
POCKET CENTER	740 mm

NOTE:

PAINT WITH CMC 99-02-95 PER CPS 80

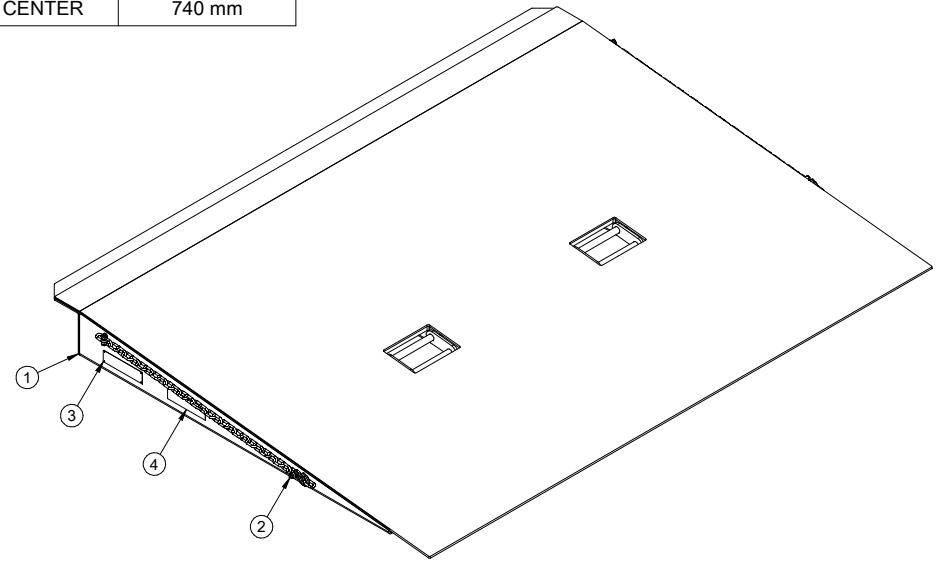
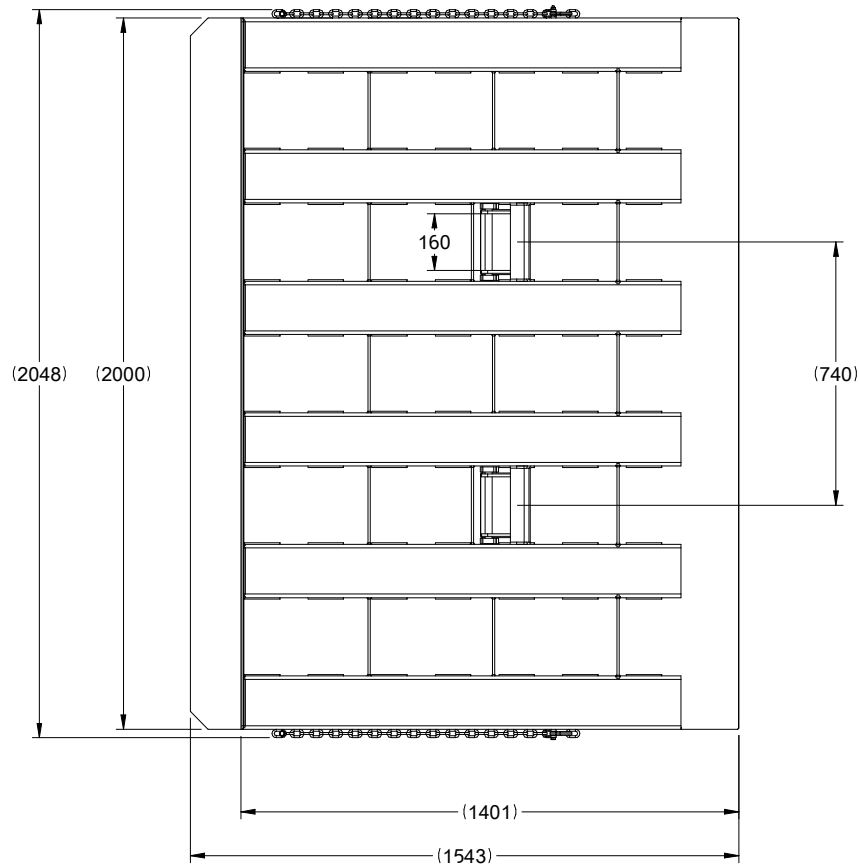

A-RENAME B-UPDATE MASS	LISTED	MSCHINDL	<p>THIS DRAWING IS THE PROPERTY OF CASCADE AND CONTAINS CONFIDENTIAL INFORMATION. DO NOT REPRODUCE OR USE WITHOUT WRITTEN APPROVAL.</p>
		JDAVIS	
		2021-08-31	CONTAINER RAMP FIXED 6500 KG
		262.kg	
SEE CASCADE ENGINEERING STANDARDS FOR DRAFTING CONVENTIONS. UNLESS OTHERWISE SPECIFIED ALL DIMENSIONS ARE IN MILLIMETERS. ALL POSITION TOLERANCES APPLY AT Ⓢ. ENVELOPE REQUIREMENT, Ⓢ, APPLIES.			1 SK-56002

METRIC