



STRONG, DEPENDABLE ATTACHMENTS AND ACCESSORIES

2/3 Atlas Court
Welshpool
Western Australia 6106

Telephone: (08) 9458 7933
Facsimile: (08) 9458 1351
ABN 67 458 625 997

DRUM TIPPER MANUAL GRAB - HYDRAULIC TIP

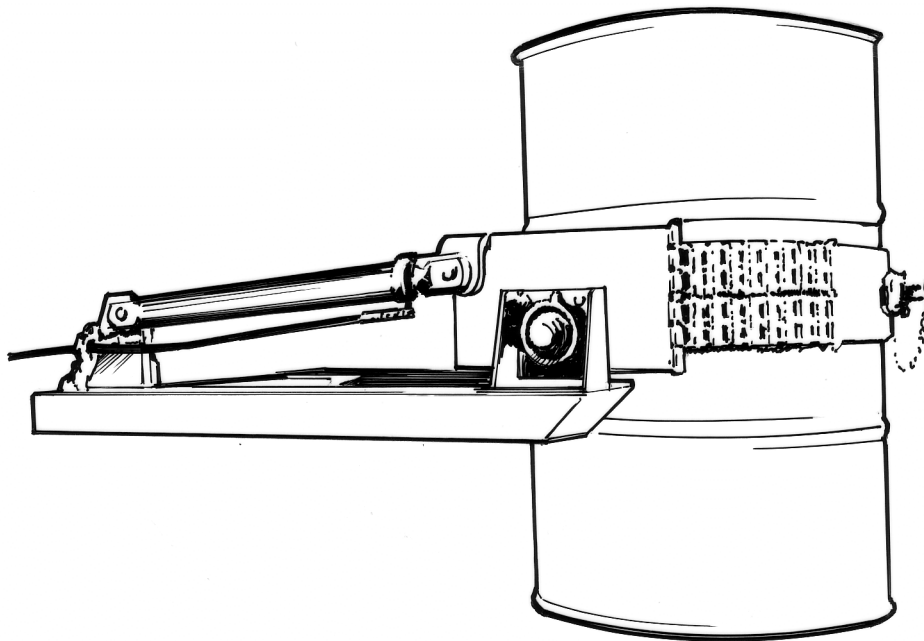

Model -	HSDTMCHT
Capacity -	500kgs
Forward rotation -	130 degrees
Unit weight -	150kgs
Paint finish -	Golden Yellow

**Manual grab and hydraulic rotate of 205 litre drums.
One auxiliary function required on the forklift.
Connected via quick release couplings. Retained by
safety chain.**